

Article Info

Received: 20 Jan 2016 | Revised Submission: 10 Feb 2016 | Accepted: 28 Feb 2016 | Available Online: 15 Mar 2016

Thermodynamic (Energy-Exergy) Analysis of Solar Assisted Power-Cooling Combined Generation Systems

Kaushalendra Kumar Dubey and R. S. Mishra***

ABSTRACT

Novel concept to produce power and cooling with the energy contained in low-temperature ($< 200^{\circ}\text{C}$), thermal resources is presented in this paper. These resources can be obtained from concentrating solar thermal energy, and from waste heat sources. The concept uses thermal energy in a low-temperature boiler to partially boil an organic type working fluid mixture. This produces rich vapor that drives an expander. The expander's output is mechanical power; however, under certain operating conditions its exhaust can be cold enough to use for cooling. An analytical study is identified expander efficiency, expander inlet conditions for determining exhaust temperature, consideration of the operating conditions of integrated solar combined power /cooling cycle. The present research provides simulated performance for improving system efficiency.

Keywords: *Energy-Exergy Analysis; Cogeneration; Combined Power Cycle; Organic Rankine Cycle.*

1.0 Introduction

Nowadays due to 40% predicted increase in energy consumption of the world, more environmental concerns and less dependency on fossil fuels, demand for sophisticated power supply options is greatly increased. Environmental concerns will be in form of global warming, acid rains, air, water and soil pollution, ozone depletion, forest devastation and radioactive substances emissions. Utilizing waste heats along with attempts to derive energy out of renewable resources as low grade thermal heat sources have motivated the use of advanced energy recovery systems.

The present research issue provides new concept and development of low GWP and ODP refrigerants based utilities for an industrial application. The simulated performance is discussed and relate to improving future modeling and system design efforts.

Cogeneration or combined heat and power (CHP) is the use of a heat engine or power station to generate electricity and useful heat at the same time. Cogeneration is a thermodynamically efficient use of fuel. In separate production of electricity, some energy must be discarded as waste heat, but in cogeneration this thermal energy is put to use.

All thermal power plants emit heat during electricity, which can be released into the natural environment through cooling towers, flue gas, or by

other means. By-product heat at moderate temperatures ($100\text{--}180^{\circ}\text{C}$, $212\text{--}356^{\circ}\text{F}$) can also be used in absorption refrigerators for cooling.

Requirements of cogeneration may be met in many ways ranging from steam and gas turbines to fuel cells and Sterling engines.

Maidment and Tozer [1] have reviewed a number of combined energy production plants operating in supermarkets. They analyzed different schemes of combined energy production including different cooling and engine technologies.

The thermodynamic cycle of the basic combined cycle consists of two power plant cycles shown in figure of combined power cycle. One is the Joule or Brayton cycle which is a gas turbine cycle and the other is Rankine cycle which is a steam turbine cycle.

The cycle 1-2-3-4-1 which is the gas turbine power plant cycle is the topping cycle. It depicts the heat and work transfer process taking place in high temperature region. As shown in Fig-1.

The cycle a-b-c-d-e-f-a which is the Rankine steam cycle takes place at a low temperature and is known as the bottoming cycle. Transfer of heat energy from high temperature exhaust gas to water and steam takes place by a waste heat recovery boiler in the bottoming cycle. During the constant pressure process 4-1 the exhaust gases in

*Corresponding Author: Department of Mechanical Engineering, Delhi Technological University, Delhi, India
(E-mail: professor_rsmishra@yahoo.co.in)

**Department of Mechanical Engineering, Delhi Technological University, Delhi, India

the gas turbine reject heat. The feed water, wet and super heated steam absorb some of this heat in the process a-b, b-c and c-d. Cogeneration systems are normally classified according to the sequence of energy use and the operating schemes adopted. A cogeneration system can be classified as either a topping or a bottoming cycle on the basis of the sequence of energy use. In a topping cycle, the fuel supplied is used to first produce power and then thermal energy, which is the by-product of the cycle and is used to satisfy process heat or other thermal requirements. Topping cycle cogeneration is widely used and is the most popular method of cogeneration.

Fig: 1. Combined Power Cycle [1]

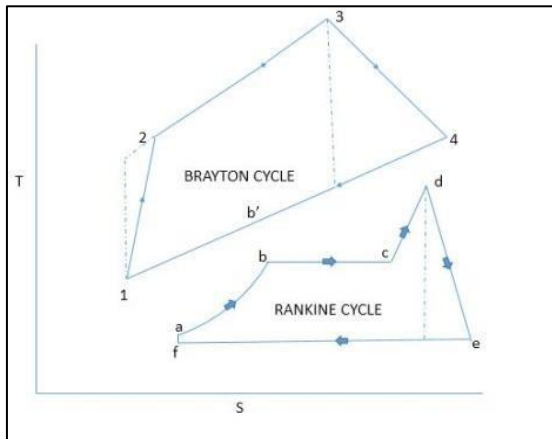

2.0 Topping Cycle

The four types of topping cycle cogeneration systems are briefly explained.

A gas turbine or diesel engine producing electrical or mechanical power followed by a heat recovery boiler to create steam to drive a secondary steam turbine. This is called a combined-cycle topping system.

The second type of system burns fuel (any type) to produce high-pressure steam that then passes through a steam turbine to produce power with the exhaust provides low-pressure process steam. This is a steam-turbine topping system.

A third type employs heat recovery from an engine exhaust and/or jacket cooling system flowing to a heat recovery boiler, where it is converted to process steam / hot water for further use.

The fourth type is a gas-turbine topping system. A natural gas turbine drives a generator. The exhaust gas goes to a heat recovery boiler that makes process steam and process heat.

3.0 Bottoming Cycle

In a bottoming cycle, the primary fuel produces high temperature thermal energy and the heat rejected from the process is used to generate power through a recovery boiler and a turbine generator. Bottoming cycles are suitable for manufacturing processes that require heat at high temperature in furnaces and kilns, and reject heat at significantly high temperatures. Typical areas of application include cement, steel, ceramic, gas and petrochemical industries. Bottoming cycle plants are much less common than topping cycle plants. The waste gases coming out of the furnace is utilized in a boiler to generate steam, which drives the turbine to produce electricity

4.0 Tri-generation

Tri-generation technology is a technology that can provide simultaneously three forms of output energy; electrical power, heating and cooling. Tri-generation is also known as CCHP (Combined Cooling, Heating and Power) or CHP (Combined Heating, Refrigeration and Power). In essence, tri-generation systems are CHP (Combined Heat and Power) or co-generation systems, integrated with a thermally driven refrigeration system to provide cooling as well as electrical power and heating.

CHP systems consist of a power system which can be an internal combustion engine driven by a fossil fuel or a biofuel, an external combustion engine or other thermally or chemically driven systems coupled to a generator which produces electricity.

A heat recovery system recovers heat from the power system and exhaust gases to be used for heating applications. Effective operation of CHP systems requires maximum utilization of both electrical power and heat.

Where there are seasonal variations in heat demand, the efficiency of CHP systems can be increased if the excess heat is used to power thermally driven refrigeration technologies.

Tri-generation systems have overall efficiencies as high as 90% compared to 33%-35% for electricity generated in central power plants.

4.1. Organic rankine cycle (ORC) for energy recovery

The ORC applies the principle of the steam Rankine cycle, but uses organic working fluid with low boiling points, instead of steam, to recover heat from a lower temperature source. The cycle consists of an expansion turbine, condenser, a pump, a boiler and a superheated (provide superheat is needed). [2]

4.2. Organic rankine cycle

Fig. 2. Tri-Generation System Layout [1]

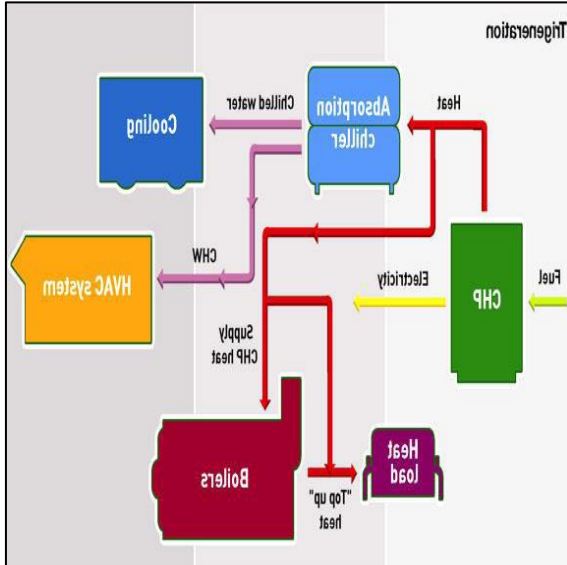

Different form of combined with ORC as a bottoming cycle, ORC with different working fluid for power plants, cement industry, desalination, process industry, furniture manufacturing industry, etc. and Wastage heat recovery

4.3. ORC working fluids

The working fluid of an organic Rankine cycle is very important. Pure working fluids such as HCFC123 (CHCl2CF3), PF5050 (CF3(CF2)3CF3), HFC-245fa (CH3CH2CHF2), HFC-245ca (CF3CHFCH2F), isobutene (((CH3)2C=CH2)), n-pentane and aromatic hydrocarbons, have been studied for organic Rankine cycles.

The slope of the saturation curve (ds/dt slope) of a working fluid in a Temperature-Entropy diagram. Working fluid classified as a Dry fluid, wet fluid or isentropic fluid, it is defined by. If $J=ds/dt$, $J.>0$ for dry fluid (pentane), $J=0$ for isentropic fluid (R11) and $J.<0$ for wet fluid (water).[3-4].

Isentropic or dry fluid was suggested for ORC to avoid liquid droplet impingement in turbine blade during the expansion.

If the fluid is too dry the expanded vapor will leave the turbine with substantial superheat, which is a waste and add to the cooling load in the condenser.

The cycle efficiency can be increased using this superheat to preheat the liquid after it leaves the feed pump and before it enters the boilers.

All components of ORC shown in fig-ORC components [4]

Fig. 3. ORC Components [2]

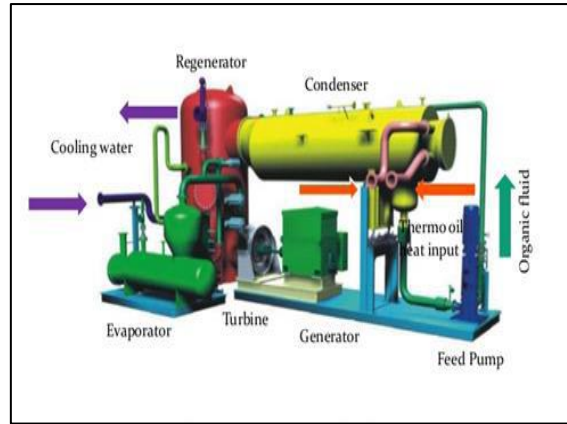

Chen et al. [3] summarized heat-transfer properties of the working fluids are of great importance. Desirable properties are: low viscosity and surface tension, low specific heat of the liquid, high thermal conductivity, high latent heat of vaporization. The evaporator enthalpy ratio i.e. the ratio of enthalpy of vaporization to the sensible enthalpy required to raise the temperature of the compressed liquid should have a high value.

Fig. 4. Temperature-Entropy Diagram of Fluids [4]

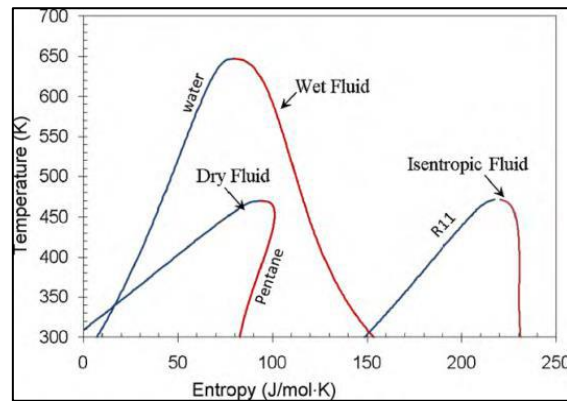

4.4. Binary fluid (NH3-H2O) thermal system [1]

The Binary fluid (NH₃-H₂O) Thermal System was 1st developed by Aleksander Kalina in the late 1970 and early 1980 for generating electricity using low to medium temperature resources. Kalina system uses ammonia-water (Binary fluid) mixture as working fluid.

This mixture is used as source for power and cooling. In this cycle ammonia is the refrigerant and water as is the absorbent due to the high difference in their boiling point and high enthalpy.

In the Kalina system, used binary fluid mixture results in a good thermal match in the boiler due to the non-isothermal boiling created by the shifting mixture composition.

Several studies have shown that the Kalina cycle performs substantially better than a steam Rankine cycle system.

A second law analysis showed that by using a binary fluid, the Kalina cycle reduced irreversibility in the boiler, resulting in improved efficiency of the cycle.

Table: 1(a). Commercialized Working Fluids [4]

S. No	Chemicals	Physical Data			
		Molecular Mass (Kg/K mol)	Normal Boiling Point Temp (T_{bp}) in $^{\circ}$ C	Critical Temp (T_{crit}) in $^{\circ}$ C	Critical Pressure (P_{crit}) in MPa
1	RC118	200.03	-6.0	115.2	2.778
2	R600a	58.12	-11.7	135	3.647
3	R114	170.92	3.6	145.7	3.289
4	R600	58.12	-0.5	152	3.796
5	R601	72.15	36.1	196.5	3.364
6	R113	187.38	47.6	214.1	3.439
7	Cyclohexane`	84.16	80.7	280.5	4.075
8	R290	44.10	-42.1	96.68	4.247
9	R407C	86.20	-43.6	86.79	4.597
10	R32	52.02	-51.7	78.11	5.784
11	R500	99.30	-33.0	105.5	4.455
12	R152a	66.05	-24.0	113.3	4.520
13	R717	17.03	-33.3	132.3	11.333
14	Ethanol	46.07	78.4	240.8	6.148
15	Methanol	32.04	64.4	240.2	8.104
16	R718	10.2	100	374	22.064
17	R134a	102.03	-26.1	101	4.059
18	R12	120.91	-29.8	112	4.114
19	R123	152.93	27.8	183.7	3.668
20	R141b	116.95	32.0	204.2	4.249
21	R245fa	134.05	15.3	154.1	3.64
22	R236fa	152.0	-1.5	124.0	3.20
23	R227ea	170.0	-17.5	102.0	2.95
24	R1234yf	114.02	-29.45	94.7	3.382

Table: 1(b). Commercialized Working Fluids [4]

S. No	Chemicals	Environmental Data		
		Atmospheric Life Time (ALT) in years	Ozone Depletion potential (ODP)	Global Warming Potential (GWP) of 100 years
1	RC118	3200	0	10225
2	R600a	0.017	0	20
3	R114	300	1.00	10040
4	R600	0.018	0	20
5	R601	0.01	0	20
6	R113	85	1.000	6130
7	Cyclohexane`	NA	NA	NA
8	R290	0.041	0	20
9	R407C	NA	0	1800
10	R32	4.9	0	675
11	R500	NA	0.738	8100
12	R152a	1.40	0	124
13	R717	0.1	0	<1
14	Ethanol	NA	NA	NA
15	Methanol	NA	NA	NA
16	R718	NA	0	<1
17	R134a	14.0	0	1430
18	R12	100	1.000	10890
19	R123	1.3	0.02	77
20	R141b	9.3	0.120	725
21	R245fa	8.8	0	820
22	R236fa	209	0	6300
23	R227ea	36.5	0	2900
24	R1234yf	NA	~0	4

One drawback of the Kalina system is the fact that high vapor fraction is needed in the boiler, however, the heat exchanger surface is easy to dry out at high vapor fraction as, resulting in lower overall heat transfer coefficients and a larger heat exchange area. Another drawback relates to the corrosives is ammonia. Impurities in liquid ammonia such as air or carbon dioxide can cause stress corrosion cracking of mild steel and also ammonia is highly corrosive towards copper and zinc.

The pump pressurized the saturated liquid (5) which is leaving from the condenser and it is sent in to the high temperature re-cuperator (6).

The liquid takes off the heat from the two phases dead vapor (3). The pressurized hot liquid (sub-cooled state) enters (1) into the vaporizer where the liquid is converted in to vapor (2) by utilizing the latent or sensible heat of the hot source (1s-2s).

The saturated vapor (2) from the vaporizer is expanded in the turbine up to its condenser pressure. The two phase mixture after giving a part of its latent heat to the incoming liquid (4) enters in to the condenser, where cooling water enters (1w), takes away all the heat available in the two-phase mixture, and leaves at higher temperature (2w).The saturated liquid is pressurized in the pump and the cycle repeats.

5.0 Combined Rankine and Refrigeration Cooling Cycle-[1]

Mezza [4] proposed novel thermodynamic cycle that uses binary mixture to produce power and refrigeration simultaneously in one loop. This cycle is a combination of Rankine power and absorption cooling cycle. Its advantages include the production of power and cooling in the same cycle, the design flexibility to produce any combination of power and refrigeration, the efficient conversion of moderate temperature heat source and the possibility of improved resource utilization compared to separate power and cooling system. The binary mixture first used was ammonia-water and later on new binary f

Fig. 6. B Fluids Were Proposed and Studied.Inary Fluid (NH3-H2O) Thermal System [1]

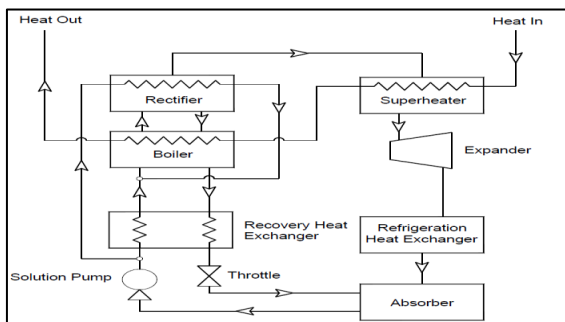
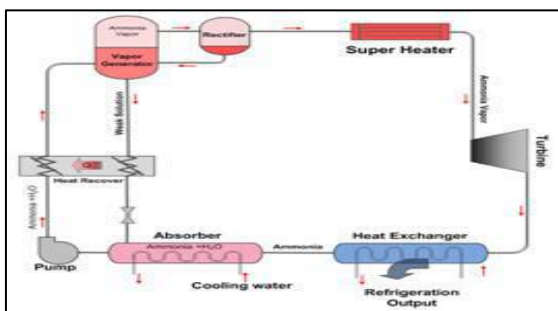

Fig. 7. Combined Rankine and Refrigeration Cooling Cycle-[1]



5.1. Energy Recovery (High-Low Grade) Technology. [3]

Three categories of wastage heat sources are distinguished with respect to the temperature level, low (<2300C), medium (230-6500C) and high (>6500C).Waste heat sites and thermal levels are listed in table of energy recovery and its sources.

5.2. Status of Energy Recovery Technology in India [3]

(a) Cement Industry

Some studies shown in Table-4 for Indian industries for 2,500 ton per day plant of cement can be used to set up a 1.6 MW waste heat recovery plant using the Organic Rankine Cycle. Based on this assumption and projected manufacturing capacity of cement industry in India, a rough potential of the electricity production from waste heat by ORC technology is estimated to be 574 MW.

Table. 3. Grade of Energy and its Sources [3]

Heat Categories	Heat Sources	Temperature in °C	Suggested recovery technology
High Grade (>650°C)	Solid waste	650-1000	Air preheating
	Nickel refining furnace	1370-1650	Steam generation for heating
	Copper reverberatory furnace	760-815	Thermoelectric and thermal PV
	Glass melting furnace	1000-1550	Heat exchanger for preheating
	Hydrogen plant	650-1000	Thermal PV
Medium Grade (230-650°C)	Steam boiler exhaust	230-480	Steam Rankine cycle
	Gas turbine exhaust	370-540	Organic Rankine cycle
	Drying and baking ovens	230-600	Thermal PV
	Catalytic crackers	425-650	Thermal PV
	Reciprocating engine exhaust	315-600	Thermoelectric
Low Grade (>230°C)	Welding and injection molding	32-88	Kalina cycle
	Hot processed liquids and solids	32-233	Organic Rankine cycle
	Drying, Baking and Curing ovens	93-230	Absorption and adsorption cooling
	Bearing	32-88	Piezoelectric

(b) Glass Industry

Typically, a 500 ton per day glass manufacturing plant will have potential for a 1 MW Organic Rankine Cycle waste heat recovery plant. The projected waste heat recovery potential through ORC in the glass industry in India is total potential estimated at around 36 MW by 2017.

(c) Iron and Steel Industry

Typically, a 6,000 ton per day steel rolling mill has a potential of generating 2.4 MW of electricity through an Organic Rankine Cycle waste heat recovery plant. The projected waste heat recovery potential through ORC in the Iron and Steel sector is total potential estimated to be around 148.4 MW by 2017.

6.0 Thermodynamic Analysis

Renewable energy sources, such as solar thermal and geothermal, biomass, municipal solid waste (MSW) and vast amounts of industrial waste heat are potentially promising energy sources capable, to meet the world electricity demand. However, the low grade heat from these sources cannot be converted efficiently to electrical power by using the conventional power generation methods. In this context, research on how to convert these low-grade temperature heat sources into electrical power is of great significance. The organic Rankine cycle (ORC), whose most important feature is the possibility of using different low temperature heat sources for small and medium power generation, has been studied by many authors. Present Literature review focus on ORC based wastage energy recovery systems, working fluid and their technological development. Hong Gao et al. [5] estimated exergy efficiencies like, 0.35, 0.40, 0.45, 0.50 and 0.55 under different critical temperature (450 to 5000C) and critical pressure (5 to 10 MPa) respectively for butane based supercritical ORC thermal system. Maria T Johansson et al [6] studied three different engines (Thermo-Electric generator, Organic Rankine cycle engine and Phase Change Material based engine) for wastage energy recovery for steel industry, and estimate conversion efficiency like 1-5%, 7.5-16% and 2.5% respectively under different temperature sources. Wang et al [7] calculated heat recovery efficiency and thermal efficiency of R123 & Toluene based ORC as 0.12% -0.10% and 0.08-0.1% respectively and conclude thermal efficiency is increased with the increase of heat recovery temperature. Omendra et al [8] estimated exergy destruction cost and capital cost of Brayton-Rankine-Kalina combine triple power system such as 40,663 to 37,416 rs and total cost decreased by 4041 ϕ /h as compare with conventional power generation system

by using SPECO techno-economic analysis approach and showed the effect of relative humidity on inlet air for exergy destruction from 30-100% of RH value. Abdul Khaliq [9] showed effect of inlet pressure and temperature on 1st and 2nd law efficiency of gas turbine tri-generation system, and discussed 1st law efficiency of cogeneration and tri-generation decreases with increases in pressure ratio but 2nd law efficiency, thermal to electrical energy ratio is increases. Bertrand F. Tchanche, et al [10] estimated 82% of overall efficiency of ocean thermal energy based ORC system with 2765 ϵ /KW of installation cost and 9-14 ϵ /KW of electrical power cost. Na Zang et al [11] proposed design of combined refrigeration and binary fluid power cycle and estimate energy and exergy efficiency 26-28 % and 55-60% respectively at temperature level of 450 OC and that performance compare with nuclear power plant exhaust used as a topping gas turbine power plant. Y Chen et al [12] compared CO2 transcritical power cycle with R123 based ORC when utilizing low grade of heat source at 1500C and 0.4kg/s of mass flow rate. The expander isentropic efficiency of both system has been estimated 80% and 70% respectively. Chen et al [3] investigated thermal performance of zeotropic mixture (70% of R134a + 30% of R32) based supercritical rankine cycle and R134a based ORC and achieved 10.77%-13.35% & 88.6%-81.64% of thermal and exergy efficiency at same temperature level of 393-453 OC respectively. The overall efficiency of both systems estimated 38.1% and 24.2%. R Shankar et al [14] performed analysis of solar integrated combined vapor power and cooling cycle for domestic and industrial level and compare both systems from high pressure and low pressure turbine are 58.75 & 91.57 KW respectively at the atmospheric and separator temperature of 300C & 1200C. Javier Rodriguez Martin et al [15] estimated 70% and 0.469 of thermal and exergy efficiency of solar parabolic collector based ORC at 2380C and 311.11 bar of temperature and pressure value. Dincer et al studied [16] the energy efficiency increases while exergy efficiency and electrical to thermal energy ratio decrease with increasing exhaust gas inlet temperature. and effect of increasing process steam pressure, energy efficiency decreases while exergy efficiency and electrical to thermal energy ratio increase. Deepak et al [17] conclude energy and exergy efficiency of different commercial fluid for wastage energy recovery system and examined 7% of theoretical thermal efficiency of new trend of refrigerants like R1234yf with the 30-90 OC range of temperature. Vijayaraghavan, et al [18] calculated 95, 96.5, 89% of thermal efficiency of Kalina thermal system with 556.5, 511, 1410C and 19.5, 3.11 & 0.572 bar of inlet turbine temperature and pressure respectively. Nobru et al. [19] Studied

,First Law efficiency on HFO-1234yf driven ORC for low to medium temperature range and found that it is potential working substance having negligible ozone depletion potential, global warming potential and found highest thermal efficiency 8.8-11.4% for expander inlet temperature range of (180-160°C) in Supercritical Organic Rankine cycle. Padilla et al [20] noticed that turbine exit quality decreases when the absorber temperature decreases in analysis of power and cooling cogeneration using ammonia-water system.

Table: 4. ORC Development in India [3]

Sector	Capacity (MW)
1. Wastage Heat Recovery In Major Industry	
a. Cement	574.2
b. Glass	35.7
c. Iron and steel	148.4
Total	758.3
2. Renewable Energy	
a. Solar thermal energy storage	1440
b. Biogas plant	2208
c. Geothermal	NA
Total	3648
Grand Total	4406.3

Although lot of work have been presented by various investigators [1-20] but still some problems are still to be analyzed in detail are as follow

The technological implementations of low-temperature ORC in an industry still awaits the arrival of a low GWP replacement fluid exiting fluid to maintain the cost advantage that can be realized by using equipment for ORC duty. The newly developed fluid 1233zd (E) could be that fluid. The medium pressure new refrigerants R1234yf and R1234ze (E) approach R134a and R245fa.. Till now there is no study about solar based combined heating, power and cooling system analysis using HFO-1234yf as working substance in Organic Rankine cycle for food process industry in India. Integrated Solar based Trilateral Flash power ORC cycle and Cogeneration Bottoming ORC cycle is most applicable in ceramics ,rice mill and sugar mill type Indian industry for low grade wastage energy recovery.

temperature heat sources into electrical power is of great significance.. The organic Rankine cycle (ORC), whose most important feature is the possibility of using different low temperature heat sources for small and medium power generation, has been studied by many authors. Present Literature review focus on ORC based wastage energy recovery systems, working fluid and their technological

development. Hong Gao et al. [5] estimated exergy efficiencies like, 0.35, 0.40, 0.45, 0.50 and 0.55 under different critical temperature (450 to 5000C) and critical pressure (5 to 10 MPa) respectively for butane based supercritical ORC thermal system. Maria T Johansson et al [6] studied three different engines (Thermo-Electric generator, Organic Rankine cycle engine and Phase Change Material based engine) for wastage energy recovery for steel industry, and estimate conversion efficiency like 1-5%, 7.5-16% and 2.5% respectively under different temperature sources. Wang et al [7] calculated heat recovery efficiency and thermal efficiency of R123 & Toluene based ORC as 0.12% -0.10% and 0.08-0.1% respectively and conclude thermal efficiency is increased with the increase of heat recovery temperature. Omendra et al [8] estimated exergy destruction cost and capital cost of Brayton-Rankine-Kalina combine triple power system such as 40,663 to 37,416 rs and total cost decreased by 4041 φ /h as compare with conventional power generation system by using SPECO techno-economic analysis approach and showed the effect of relative humidity on inlet air for exergy destruction from 30-100% of RH value. Abdul Khaliq [9] showed effect of inlet pressure and temperature on 1st and 2nd law efficiency of gas turbine tri-generation system, and discussed 1st law efficiency of cogeneration and tri-generation decreases with increases in pressure ratio but 2nd law efficiency, thermal to electrical energy ratio is increases. Bertrand F. Tchanche, et al [10] estimated 82% of overall efficiency of ocean thermal energy based ORC system with 2765 ε /KW of installation cost and 9-14 ε /KW of electrical power cost. Na Zang et al [11] proposed design of combined refrigeration and binary fluid power cycle and estimate energy and exergy efficiency 26-28 % and 55-60% respectively at temperature level of 450 OC and that performance compare

7.0 Research Methodology

A general methodology is proposed here. It comprises three steps. (1) data collection, (2) data analysis and (3) Result Analysis. At the first step, the operating conditions are set and all the data: thermo physical, safety, environmental and calculated properties concerning different candidates are collected. The data are then analyzed at the second step. At this phase, the criteria are classified starting from the most critical ones and the process is done sequentially. At each sub-step, all the fluids are screened using the criterion and before going to the next criterion, the fluids are put in two groups: those which fulfil the criteria (These criteria include good heat transfer properties, non-toxicity, non-flammability, high efficiency, availability and low

cost, low vapor specific volume) and those which do not. At the last step, the best thermodynamic systems should come out followed by some alternatives.

The main objective of research work to perform Energy-Exergy analysis of integrated solar energy based wastage heat recovery system (low and medium temperature) using combined heating-power and cooling system for industrial application and following energy systems are considered for above objectives in present investigations

- 1) Energy-Exergy analysis of ORC system (Sub critical, Trans-critical and Supercritical ORC systems)
- 2) Energy-Exergy analysis of Integrated solar combined (Heating-Power system) power energy recovery system, Topping and Bottoming type both.
- 3) Energy-Exergy analysis of ORC with reheating.
- 4) Energy-Exergy analysis of ORC with regenerative.
- 5) Energy-Exergy analysis of ORC Tri-generation system.
- 6) Energy-Exergy analysis of trilateral flash type ORC system.

8.0 Conclusions

In general conventional steam cycle operates in medium to high temperature and cannot be cost effective at smaller scale or low temperature resources. In The low medium temperature range Organic Rankine, Kalina, Chen, and Transcritical cycles have demonstrated.

From the literature, it is evident that an integrated approach towards operational efficiency improvements of existing systems, reduction of losses in operational mechanisms, end-use efficiency and also making use of waste heat recovery technologies are very much essential for energy conservation.

The organic Rankine cycle applications in waste heat recovery. Working fluid properties and selection (including pure fluids and mixtures) was reviewed. Also some important physical properties of the working fluids for ORC and the performance of the system were introduced. Different applications of ORC systems including solar thermal, biomass ORC, solar thermal reverse osmosis desalination, geothermal application, and waste heat recover from industrial process were intensively investigated. The paper also presented the different employed expander in the ORC system and introduced many factors which should be considered such as the power capacity, isentropic efficiency, cost and complexity their application range. Environmental concern over climate change as well as energy price is reasons supporting application of the waste heat recover by the ORC technology. Different Waste Heat Recovery

Systems (WHRS) have been experimented to analyze the effect of various parameters of energy savings. Mathematical modeling by using MATLAB and fluid properties and thermodynamic property estimation using NIST REFPROP 8.0/Modelica software are used in the present investigation.

References

- [1] G. G. Maidment, R. M. Tozer, Combined cooling heat and power in supermarkets, *Applied Thermal Engineering*, 22, 2002, 653–665
- [2] www.orccycle.be (Last checked May 2013)
- [3] Turboden, www.turboden.eu/en/products/products-hr.php. (Last Accessed August 2014).
- [4] V. Maizza, A. Maizza, Working fluids in non-steady flows for waste energy recovery systems, *Applied Thermal Energy*, 16, 1996, 579-590
- [5] Hong Gao, Chao Liu, Chao He, Performance analysis and working fluid selection of a supercritical ORC for low grade wastage heat recovery, *Energies*, 23, 2012, 3233-3247
- [6] Maria T Johansson, Mats Soderstrom, Electricity generation from low grade temperature industrial excess heat an opportunity for steel industry, proceeding of Int, Conference, Sweden, 2013, 1-18.
- [7] EH Wang, HG Zhang, BY Fan, MG Ouyang, Y Zhao, QH. Mu, Study of working fluid selection of organic Rankine cycle (ORC) for engine waste heat recovery. *Journal of Energy*, Elsevier, 36, 2011, 3406–18.
- [8] Omendra Singh, SC Kaushik, Thermodynamic evaluation and optimization of a Brayton-Rankine-Kalina combined triple power cycle, *Journal of energy conversion and management*, 71, 2013, 32-42
- [9] Abdul Khaliq, Exergy analysis of gas turbine trigeneration system for combined production of power heat and refrigeration. *Int. Journal of Refrigeration*, Elsevier, 32, 2009, 534-545

- [10] Bertrand F. Tchanche, Gr Lambrinos, Low grade heat conversion into power using ORC-A Review of various application, *Journal of renewable and sustainable energy reviews*, Elsevier, 15, 2011, 3963-3979
- [11] Na Zang, Noam Lior, Methodology for thermal design of novel combined refrigeration / power binary fluid systems, *Journal of refrigeration*, Elsevier, 30, 2007, 1072-1085.
- [12] Y Chen, P Lundqvist, A Johansson, A comparative study of the CO₂ transcritical power cycle compared with an ORC with R123 as working fluid in waste recovery, *Journal of applied thermal energy*, 26, 2006, 2142-2147.
- [13] H Chen, DY Goswami, EK. Stefanakos, A supercritical rankine cycle using zeotropic mixture working fluids for the conversion of low-grade heat into power, *Journal of energy*, Elsevier, 36, 2011, 549-55
- [14] R Shankar, T Srinivas, Parametric optimization of vapor power and cooling cycle, 4th Int. Conference on advances in energy research, Elsevier, 54, 2014, 135-141